

AN8488SB

3-phase full-wave motor driver and DC motor BTL driver IC

■ Overview

The AN8488SB is a motor driver IC incorporating a 3-phase full-wave motor driver and DC motor BTL driver IC with a reverse rotation brake/short brake changeover function. It is encapsulated into a high allowable power dissipation package (with copper block).

■ Features

- 3-phase full-wave and snubberless
- FG output
- Current limit
- Reverse rotation prevention
- Thermal protection circuit built-in

■ Applications

- Various types of optical disk drive

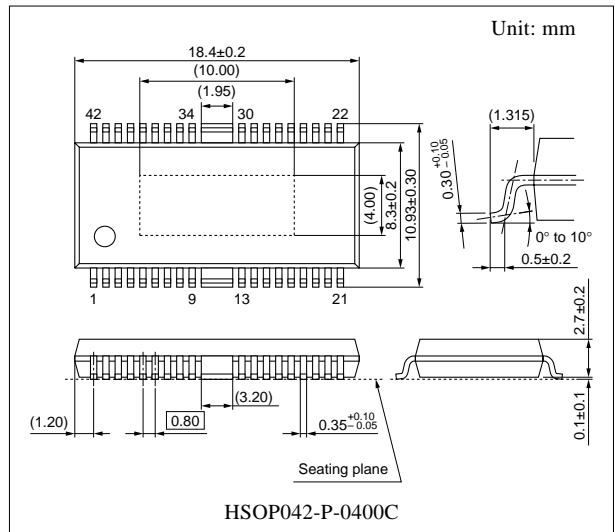

■ Block Diagram

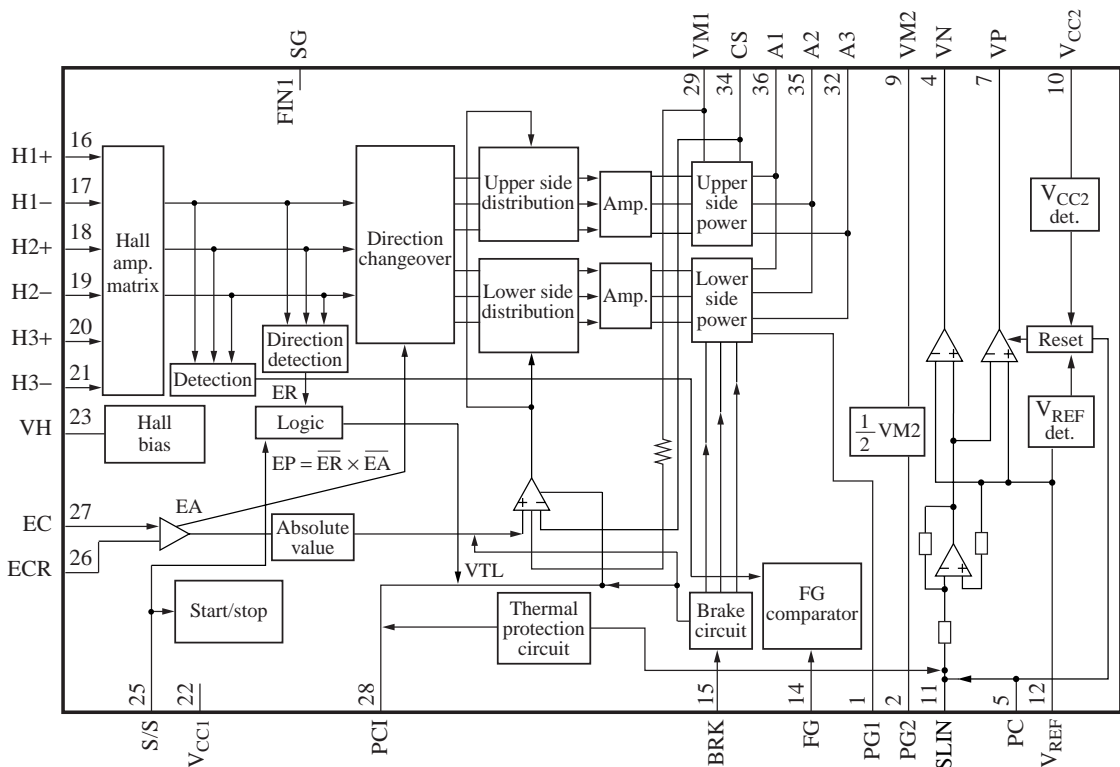

■ Pin Descriptions

Pin No.	Symbol	Description	Pin No.	Symbol	Description
1	PG1	SPD block power GND pin	19	H2-	Hall element-2 negative input pin
2	PG2	Driver block power GND pin	20	H3+	Hall element-3 positive input pin
3	N.C.	N.C.	21	H3-	Hall element-3 negative input pin
4	VN	Driver block inverted output pin	22	V _{CC1}	SPD block supply voltage pin
5	PC	Driver block power cut pin	23	VH	Hall bias pin
6	N.C.	N.C.	24	N.C.	N.C.
7	VP	Driver block forward output pin	25	SS	Start/stop changeover pin
8	N.C.	N.C.	26	ECR	Torque command reference input pin
9	VM2	Driver block motor power supply pin	27	EC	Torque command input pin
10	V _{CC2}	Driver block supply voltage pin	28	PCI	Current feedback phase compensation pin
11	SLIN	Driver block input pin	29	VM1	SPD block motor supply voltage pin
12	V _{REF}	Driver block reference input pin	30	N.C.	N.C.
13	N.C.	N.C.	31	N.C.	N.C.
14	FG	FG signal output pin	32	A3	A3 phase output pin
15	BRK	Brake mode setting pin	33	N.C.	N.C.
16	H1+	Hall element-1 positive input pin	34	CS	Current det. pin
17	H1-	Hall element-1 negative input pin	35	A2	A2 phase output pin
18	H2+	Hall element-2 positive input pin	36	A1	A1 phase output pin
FIN1	SG	Signal GND pin	FIN2		

■ Absolute Maximum Ratings

Parameter	Symbol	Rating	Unit
Supply voltage	V _{CC1}	7.0	V
	V _{CC2}	14.0	
	V _{M1} , V _{M2}		
Output voltage 1 *4	V _{O1(n)}	- 0.3 to V _{M1} + 0.4	V
Output voltage 2 *5	V _{O2(n)}	- 0.3 to V _{M2} + 0.4	V
Control signal input voltage *4	V _(n)	0 to V _{CC1}	V
Supply current	I _{CC1}	30	mA
Output current *3	I _{O(n)}	±1 200	mA
Hall bias current	I _{HB}	50	mA
Power dissipation *2	P _D	786	mW
Operating ambient temperature *1	T _{opr}	-20 to +75	°C
Storage temperature *1	T _{stg}	-55 to +150	°C

Note) Do not apply external currents or voltages to any pins not specifically mentioned.

For circuit currents, '+' denotes current flowing into the IC, and '-' denotes current flowing out of the IC.

*1: Except for the operating ambient temperature and storage temperature, all ratings are for T_a = 25°C.

*2: The power dissipation shown is the value of independent IC without a heat sink at T_a = 75°C. Refer to the P_D — T_a curves of the "■ Application Notes" for details.

■ Absolute Maximum Ratings (continued)

Note) *3: n = 4, 7, 32, 35, 36

*4: n = 32, 35, 36

*5: n = 4, 7

*6: n = 5, 11, 12, 15, 25, 26, 27

■ Recommended Operating Range

Parameter	Symbol	Range	Unit
Supply voltage	V_{CC1}	4.25 to 5.5	V
	V_{CC2}	4.5 to 13.5	
	V_{M1}, V_{M2}		

■ Electrical Characteristics at $T_a = 25^\circ\text{C}$

Parameter	Symbol	Conditions	Min	Typ	Max	Unit
Overall						
Circuit current 1	I_{CC1}	$V_{CC1} = 5\text{ V}$, SS: at low	—	0	0.1	mA
Circuit current 2	I_{CC2}	$V_{CC2} = 12\text{ V}$, SS: at low	—	60	200	μA
Start/stop						
Start voltage	V_{START}	Voltage with which a circuit operates at $V_{CC1} = 5\text{ V}$ and $L \rightarrow H$	2.7	—	—	V
Stop voltage	V_{STOP}	Voltage with which a circuit becomes off at $V_{CC1} = 5\text{ V}$ and $H \rightarrow L$	—	—	0.7	V
Medium voltage	V_{MED}	Voltage with which V_{PC1} becomes low at $V_{CC1} = 5\text{ V}$ and $EC = 0\text{ V}$	1.425	1.65	1.89	V
<Spindle block>						
Hall bias						
Hall bias voltage	V_{HB}	$V_{CC1} = 5\text{ V}$, $I_{HB} = 20\text{ mA}$	0.7	1.2	1.6	V
Hall amplifier						
Input bias current	I_{BH}	$V_{CC1} = 5\text{ V}$	—	1	5	μA
In-phase input voltage range	V_{HBR}	$V_{CC1} = 5\text{ V}$	1.5	—	4.0	V
Minimum input level	V_{INH}	$V_{CC1} = 5\text{ V}$	60	—	—	mV[p-p]
Torque command						
In-phase input voltage range	EC	$V_{CC1} = 5\text{ V}$	0.5	—	3.9	V
Offset voltage	EC_{OF}	$V_{CC1} = 5\text{ V}$	-100	0	100	mV
Dead zone	EC_{DZ}	$V_{CC1} = 5\text{ V}$	25	75	125	mV
Input current	EC_{IN}	$V_{CC1} = 5\text{ V}$, $EC = ECR = 1.65\text{ V}$	-5	-0.25	—	μA
Input/output gain	A_{CS}	$V_{CC1} = 5\text{ V}$, $R_{CS} = 0.6\ \Omega$	0.75	1.0	1.25	A/V
Output						
High-level output saturation voltage	V_{OH}	$V_{CC1} = 5\text{ V}$, $I_O = -300\text{ mA}$	—	0.9	1.6	V
Low-level output saturation voltage	V_{OL}	$V_{CC1} = 5\text{ V}$, $I_O = 300\text{ mA}$	—	0.2	0.6	V
Torque limit current	I_{TL}	$V_{CC} = 5\text{ V}$, $R_{CS} = 0.6\ \Omega$	400	500	600	mA

■ Electrical Characteristics at $T_a = 25^\circ\text{C}$ (continued)

Parameter	Symbol	Conditions	Min	Typ	Max	Unit
<Spindle block> (continued)						
FG						
FG output high-level	FG_H	$V_{CC1} = 5\text{ V}$, $I_{FG} = -0.01\text{ mA}$	3.0	—	V_{CC1}	V
FG output low-level	FG_L	$V_{CC1} = 5\text{ V}$, $I_{FG} = 0.01\text{ mA}$	—	—	0.5	V
In-phase input voltage range	V_{FGR}	$V_{CC1} = 5\text{ V}$, Input D-range at H2+, H2-	1.5	—	3.0	V
FG hysteresis width	H_{FG}	$V_{CC1} = 5\text{ V}$	1	10	20	mV
Brake circuit						
Short brake model level	V_{SBR}	$V_{CC1} = 5\text{ V}$	—	—	1.0	V
Reverse rotation brake mode level	V_{RBR}	$V_{CC1} = 5\text{ V}$	3.5	—	—	V
Short brake start level	V_{SBRL}	$V_{CC1} = 5\text{ V}$, $ECR = 1.65\text{ V}$	1.65	1.74	—	V
Short brake current	I_{SBR}	$V_{CC1} = 5\text{ V}$	60	90	—	mA
<Driver block>						
Driver $R_L = 16\ \Omega$						
Output offset voltage	V_{DROF}	SL IN = 1.65 V	-150	0	+150	mV
+ gain	G_{SL+}	R IN = 10 k Ω	21	23	25	dB
+/- relative gain	G_{SL}		-0.7	0	+0.7	dB
Output D range '+'	V_{O+}	SL IN = 3.3 V	9.3	10.0	—	V
Output D range '-'	V_{O-}	SL IN = 0 V	—	-10.0	-9.3	V
Power cut operation						
High-level PC threshold voltage	V_{PCH}	$V_{CC2} = 12\text{ V}$	2.9	—	—	V
Low-level PC threshold voltage	V_{PCL}	$V_{CC2} = 12\text{ V}$	—	—	1.0	V
PC input current	I_{PC}	$V_{CC2} = 12\text{ V}$, PC = 5 V	—	100	200	μA
Reset circuit						
Reset operation release supply voltage	V_{RST}		—	—	4.5	V
V_{REF} detection voltage	V_R		1.35	—	—	

• Design reference data

Note) The characteristics listed below are theoretical values based on the IC design and are not guaranteed.

Parameter	Symbol	Conditions	Min	Typ	Max	Unit
Thermal protection						
Thermal protection operating temperature	T_{SDON}	$V_{CC1} = 5\text{ V}$	—	160	—	$^\circ\text{C}$
Thermal protection hysteresis width	ΔT_{SD}	$V_{CC1} = 5\text{ V}$	—	45	—	$^\circ\text{C}$
Sled block supply voltage						
Sled block supply voltage detection hysteresis width	ΔV_{HD}		—	0.2	—	V

■ Usage Notes

1. Use the V_{CC2} at $V_{CC2} \geq V_{M2}$. And use power supply always at on state. Otherwise it will cause malfunction.
2. On driver gain setting of driver block.
Voltage gain of power amplifier: 23 dB

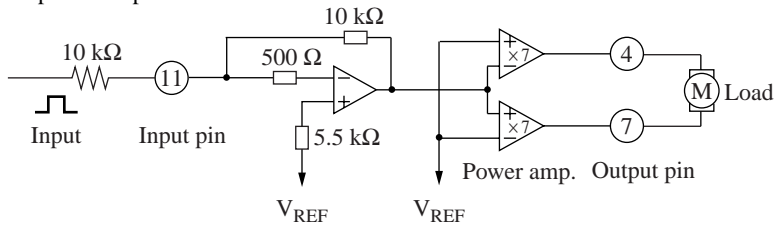

3. On operation mode of mute:

	PC	
	H	L (Open)
Driver output	Active	Mute

4. On SS pin mode:

	SS		
	H	M	L (Open)
Spindle block	On	Off	Off
Driver block	On	On	Off

5. On brake mode of spindle block:

	BRK	
	H	L (Open)
EC < ECR	Acceleration	Acceleration
EC > ECR	Reverse rotation brake	Short brake

6. Take time to check the characteristics on use.
When changing an external circuit constant for use, consider not only static characteristics, but also transient characteristics and external parts with respect to the characteristics difference among ICs so that you can get enough margin.
7. Avoid short-circuit between output pin and power supply, output pin and GND (line-to-supply and line-to-ground fault) and output pins (load short-circuit). Otherwise the IC will be damaged and is likely to get fired.
8. Be cautious on a dip soldering. Prior study is required.

■ Application Notes

- $P_D - T_a$ curves of HSOP042-P-0400

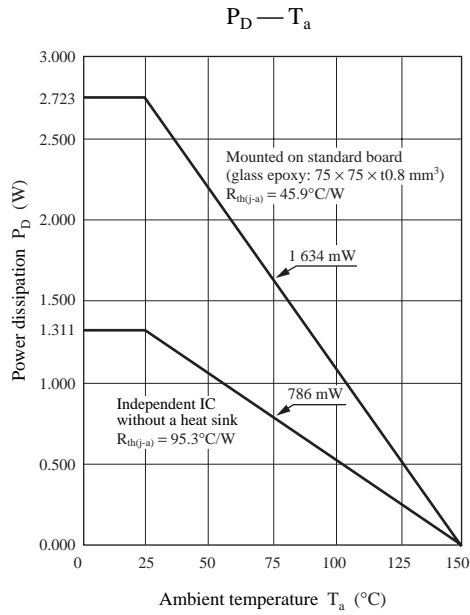

- Phase conditions between Hall input and output current

Phase of Hall pin			
	H1+	H2+	H3+
A	H	M	L
B	H	L	M
C	M	L	H
D	L	M	H
E	L	H	M
F	M	H	L

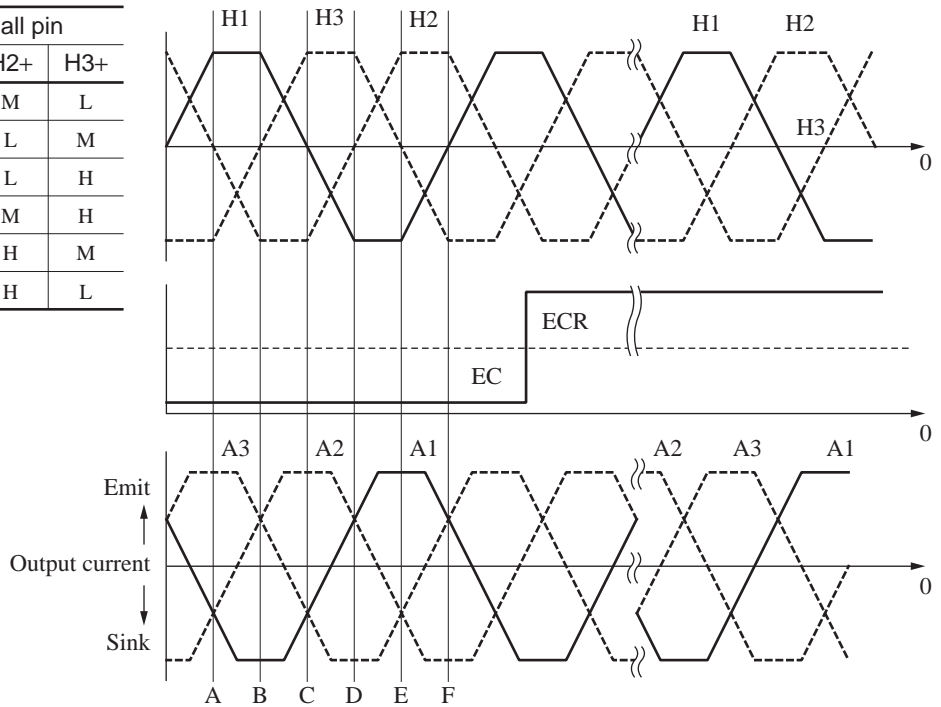

■ Application Notes (continued)

• Power consumption calculation method

You can find a rough value of electric power to be consumed in the IC in the following method and the use of EXCEL (computer soft ware) will enable you to put it on a graph.

Calculating formula:

(Spindle block)

1. Let an induced voltage generated in each phase as below:

(Reference to a motor center point)

$$E_{A1} = E_O \times \sin(X) \cdots (1)$$

$$E_{A2} = E_O \times \sin(X+120) \cdots (2)$$

$$E_{A3} = E_O \times \sin(X+240) \cdots (3)$$

X: Phase angle

2. Let a current flowing in each phase as below:

$$I_{A1} = I_O \times \sin(X) \cdots (4)$$

$$I_{A2} = I_O \times \sin(X+120) \cdots (5)$$

$$I_{A3} = I_O \times \sin(X+240) \cdots (6)$$

3. The voltages generated by a wire-wound resistance of a motor are:

$$V_{R1} = I_{A1} \times R \cdots (7)$$

$$V_{R2} = I_{A2} \times R \cdots (8)$$

$$V_{R3} = I_{A3} \times R \cdots (9)$$

4. In each phase, add the voltage generated by an induced voltage and that by a wire-wound resistance.

$$V_{A1}' = (1) + (4)$$

$$V_{A2}' = (2) + (5)$$

$$V_{A3}' = (3) + (6)$$

5. As the lowest voltage in each phase angle must be 0 V, you can get the voltage to be generated in each phase by means of subtracting the lowest voltage from the voltage of the remaining two phases.

$$V_{A1} = V_{A1}' - \text{MIN}(V_{A1}', V_{A2}', V_{A3}') \cdots (10)$$

$$V_{A2} = V_{A2}' - \text{MIN}(V_{A1}', V_{A2}', V_{A3}') \cdots (11)$$

$$V_{A3} = V_{A3}' - \text{MIN}(V_{A1}', V_{A2}', V_{A3}') \cdots (12)$$

6. Subtract the supply voltage from each phase's voltage found in item 5 and then multiply it by each phase's current, so that you can get the power consumption of the spindle block.

$$P_{SPD} = \sum_{n=1}^3 (12 - V_{An}) \times I_{An}$$

(Driver block)

$$P_{SL} = (V_{M2} - I_O \cdot R) \times I_O$$

V_{M2} : Motor power supply voltage I_O : Output current R : Wire wound resistor

• Theory of thermal resistance

A chip temperature or the fin temperature can be understood in the same way as Ohm's Law.

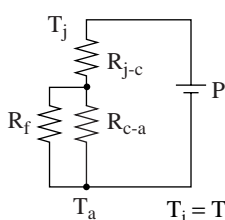

T_j : Chip temperature

T_a : Ambient temperature

P : Electric power generated by IC

R_{j-c} : Thermal resistance between a chip and a package

R_{c-a} : Thermal resistance between a package and a surface of a heat sink or free air

$$T_j = T_a + P \times (R_{j-c} + R_{c-a})$$

Make sure that T_j does not exceed 150°C.

If it exceeds 150°C, you can suppress the rise of a chip temperature by adding a heat sink which is equivalent to R_f in the above figure.

$$T_j = T_a + P \times (R_{j-c} + R_{c-a})$$

A package surface and the fin are available for a temperature measurement. But the fin part is recommendable for measurement because a package surface measurement does not always promise you a consistent measuring result.

Note) What has been mentioned above is true to a stationary state, not to a transient state.

■ Application Circuit Example

